

In The Name of God

Enjoy Mathematics



International Math Kangaroo 2016

Grades 7 & 8

3 Point Problems	1 to 10
4 Point Problems	11 to 20
5 Point Problems	21 to 30



7. In my school, 60 % of the teachers get to school by bike, which is 45 teachers. Only 12 % of the teachers use their car to get to school. How many teachers use their car to get to school?

- (A) 4 (B) 6 (C) 9 (D) 10 (E) 12

8. What is the shaded area?

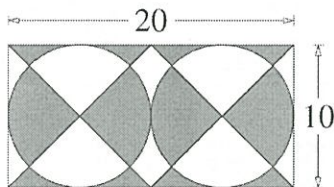

- (A) 50 (B) 80 (C) 100 (D) 120 (E) 150

9. Two pieces of rope have length 1 m and 2 m. Alex cuts the pieces into several parts. All the parts have equal length. Which of the following could not be the total number of parts he obtains?

- (A) 6 (B) 8 (C) 9 (D) 12 (E) 15

10. Four towns P, Q, R and S are connected by roads, as shown. A race uses each road exactly once. The race starts at S and finishes at Q. How many possible routes are there for the race?

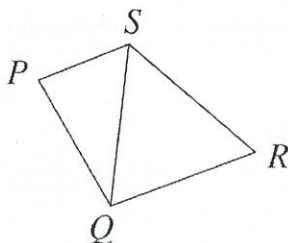

- (A) 10 (B) 8 (C) 6 (D) 4 (E) 2

4 Point Problems

11. The diagram shows four identical rectangles placed inside a square. The perimeter of each rectangle is 16 cm. What is the perimeter of the square?

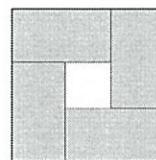

The perimeter

- (A) 16 cm (B) 20 cm (C) 24 cm (D) 28 cm (E) 32 cm

12. Petra has 49 blue beads and one red bead. How many beads must Petra remove so that 90% of her beads are blue?

- (A) 4 (B) 10 (C) 29 (D) 39 (E) 40

13. Which of the following fractions has a value closest to $\frac{1}{2}$?

- (A) $\frac{25}{79}$ (B) $\frac{27}{59}$ (C) $\frac{29}{57}$ (D) $\frac{52}{79}$ (E) $\frac{57}{92}$

14. Ivor writes down the results of the quarter-finals, the semi-finals and the final of a knock-out tournament. The results are (not necessarily in this order): Bart beat Antony, Carl beat Damien, Glen beat Henry, Glen beat Carl, Carl beat Bart, Ed beat Fred and Glen beat Ed. Which pair played in the final?

- (A) Glen and Henry (B) Glen and Carl (C) Carl and Bart
 (D) Glen and Ed (E) Carl and Damien

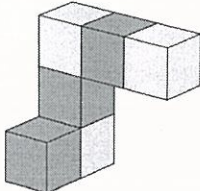
15. Anne has glued some cubes together, as shown.  She rotates the solid to look at it from different angles. Which of the following can she not see?

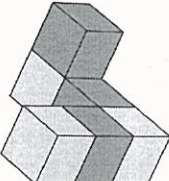
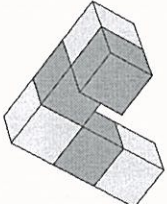
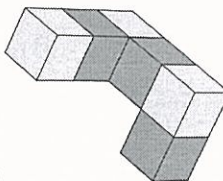
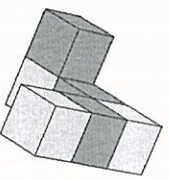
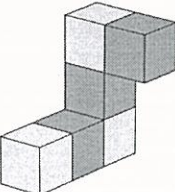
- (A)  (B)  (C) 
 (D)  (E) 

16. Tim, Tom and Jim are triplets (three brothers born on the same day). Their twin brothers John and James are 3 years younger. Which of the following numbers could be the sum of the ages of the five brothers?

- (A) 36 (B) 53 (C) 76 (D) 89 (E) 92

17. A 3 cm wide rectangular strip of paper is grey on one side and white on the other. Maria folds the strip, as shown.

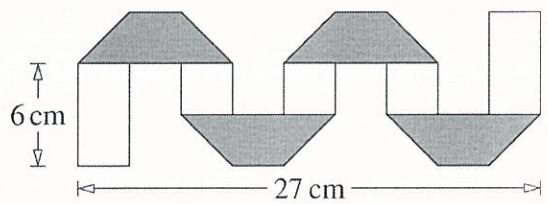

the strip, as shown. ← 27 cm → The grey trapeziums are identical. What is the length of the original strip?

- (A) 36 cm (B) 48 cm (C) 54 cm (D) 57 cm (E) 81 cm

18. Two kangaroos Jum and Per start to jump at the same time, from the same point, in the same direction. After that, they make one jump per second. Each of Jum's jumps is 6 m in length. Per's first jump is 1 m in length, the second is 2 m, the third is 3 m, and so on. After how many jumps does Per catch Jum?

- (A) 10 (B) 11 (C) 12 (D) 13 (E) 14

19. Seven standard dice are glued together to make the solid shown. The faces of the dice that are glued together have the same number of dots on them. How many dots are on the surface of the solid?

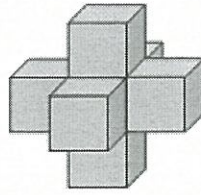

solid?

- (A) 24 (B) 90 (C) 95 (D) 105 (E) 126

20. There are 20 students in a class. They sit in pairs so that exactly one third of the boys sits with a girl, and exactly one half of the girls sits with a boy. How many boys are there in the class?

- (A) 9 (B) 12 (C) 15 (D) 16 (E) 18

5 Point Problems

21. Inside a square of area 36, there are shaded regions as shown. The total shaded area is 27.

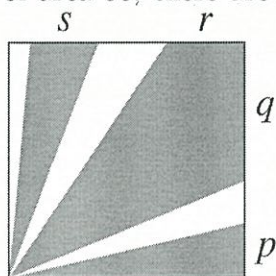

What is $p + q + r + s$?

- (A) 4 (B) 6 (C) 8 (D) 9 (E) 10

22. Theo's watch is 10 minutes slow, but he believes that it is 5 minutes fast. Leo's watch is 5 minutes fast, but he believes that it is 10 minutes slow. At the same moment, each of them looks at his own watch. Theo thinks it is 12:00. What time does Leo think it is?

- (A) 11:30 (B) 11:45 (C) 12:00 (D) 12:30 (E) 12:45

23. Twelve girls met in a café. On average, they ate 1.5 cup-cakes. None of them ate more than two cup-cakes and two of them had only mineral water. How many girls ate two cup-cakes?

- (A) 2 (B) 5 (C) 6 (D) 7 (E) 8

24. Little Red Riding Hood is delivering waffles to three grannies. She starts with a basket full of waffles. Just before she enters each of the grannies' houses, the Big Bad Wolf eats half of the waffles in her basket. When she leaves the third granny's house, she has no waffles left. She delivers the same number of waffles to each granny. Which of the following numbers definitely divides the number of waffles she started with?

- (A) 4 (B) 5
(C) 6 (D) 7
(E) 9

25. The cube below is divided into 64 small cubes. Exactly one of the small cubes is grey. On the first day, the grey cube changes all its neighbouring small cubes to grey (two cubes are neighbours if they have a common face). On the second day, all the grey cubes do the same thing. How many grey cubes are there at the end of the second day?

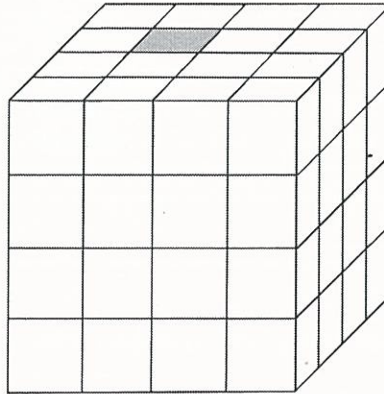

cubes are there at the end of the second day?

- (A) 11 (B) 13 (C) 15 (D) 16 (E) 17

26. Several different positive integers are written on a blackboard. The product of the smallest two of them is 16. The product of the largest two is 225. What is the sum of all the integers?

- (A) 38 (B) 42 (C) 44 (D) 58 (E) 243

27. The diagram shows a pentagon. Sepideh draws five circles with centres A, B, C, D, E such that the two circles on each side of the pentagon touch. The lengths of the sides of the pentagon are given. Which point is the centre of the largest circle that she draws?

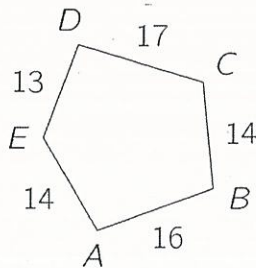

- (A) A (B) B (C) C (D) D (E) E

28. Katie writes a different positive integer on each of the fourteen cubes in the pyramid. The sum of the nine integers written on the bottom cubes is equal to 50. The integer written on each other cube is equal to the sum of the integers written on the four cubes underneath it. What is the greatest possible integer that can be written on the top cube?



possible integer that can be written on the top cube?

- (A) 80 (B) 98 (C) 104 (D) 110 (E) 118

29. A train has five carriages, each containing at least one passenger. Two passengers are said to be "neighbours" if either they are in the same carriage or they are in two adjacent carriages. Each passenger has either exactly five or exactly ten "neighbours". How many passengers are there in the train?

- (A) 13 (B) 15 (C) 17 (D) 20
 (E) There is more than one possibility.

30. A $3 \times 3 \times 3$ cube is built from 15 black cubes and 12 white cubes. Five faces of the larger cube are shown.

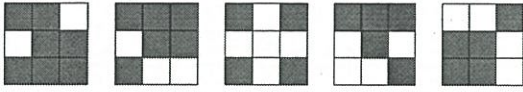

Which of the following is the sixth face of the large cube?

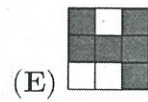
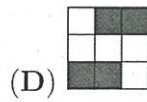
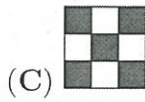
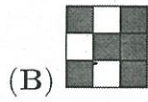
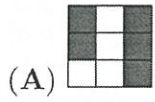



دبیرخانه ریاضیات کانگورو

مؤسسه فرهنگی فاطمی

دبیرخانه ریاضیات کانگورو در ایران

تهران، میدان فاطمی، خیابان جویبار، خیابان میرهادی شرقی، پلاک ۱۴

تلفن: ۸۸۹۴۵۵۴۵

www.mathkangaroo.ir